

# AVENUE S PROPERTIES - REPLAT OF TRACTS A, C AND D

BEING A REPLAT OF TRACTS A, C AND D, AS SHOWN ON THE PLAT OF AVENUE S PROPERTIES,  
AS RECORDED IN PLAT BOOK 105, PAGES 193 THROUGH 195, PUBLIC RECORDS OF PALM BEACH COUNTY, FLORIDA  
LYING IN SECTION 32, TOWNSHIP 42 SOUTH, RANGE 43 EAST  
CITY OF RIVIERA BEACH, PALM BEACH COUNTY, FLORIDA

STATE OF FLORIDA)  
COUNTY OF PALM BEACH)

THIS PLAT WAS FILED FOR RECORD  
AT \_\_\_\_\_ M. THIS  
\_\_\_\_\_ DAY OF \_\_\_\_\_ 2022  
AND DULY RECORDED IN PLAT BOOK  
\_\_\_\_\_ ON PAGES \_\_\_\_\_  
THRU \_\_\_\_\_.

JOSEPH ABRUZZO  
CLERK OF THE CIRCUIT COURT  
AND COMPTROLLER OF PALM BEACH COUNTY

BY: \_\_\_\_\_ D.C.

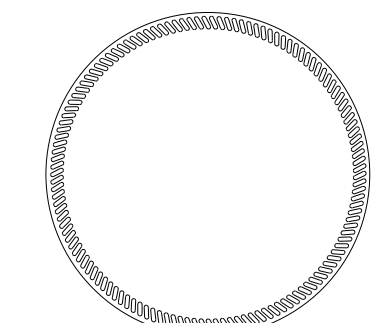

CLERK OF THE CIRCUIT COURT AND  
COMPTROLLER OF PALM BEACH COUNTY

**SHEET 1 OF 2**

## DEDICATIONS AND RESERVATIONS

STATE OF FLORIDA)  
COUNTY OF PALM BEACH)

KNOW ALL MEN BY THESE PRESENTS THAT SFG ISF RIVIERA MLK, LLC, A DELAWARE LIMITED LIABILITY COMPANY, AUTHORIZED TO DO BUSINESS IN FLORIDA, OWNER OF THE LAND SHOWN HEREON AS AVENUE S PROPERTIES - REPLAT OF TRACTS A, C AND D, BEING A REPLAT OF TRACTS A, C AND D, AS SHOWN ON THE PLAT OF AVENUE S PROPERTIES, AS RECORDED IN PLAT BOOK 105, PAGES 193 THROUGH 195, PUBLIC RECORDS OF PALM BEACH COUNTY, FLORIDA, LYING IN SECTION 32, TOWNSHIP 42 SOUTH, RANGE 43 EAST, CITY OF RIVIERA BEACH, PALM BEACH COUNTY, FLORIDA, BEING MORE PARTICULARLY DESCRIBED AS FOLLOWS:

TRACTS A, C AND D OF AVENUE S PROPERTIES PLAT, ACCORDING TO THE PLAT THEREOF, AS RECORDED IN PLAT BOOK 105, PAGES 193 THROUGH 195, OF THE PUBLIC RECORDS OF PALM BEACH COUNTY, FLORIDA.

CONTAINING A TOTAL OF 390,685 SQUARE FEET OR 8.97 ACRES, MORE OR LESS.

HAS CAUSED THE SAME TO BE SURVEYED AND PLATTED AS SHOWN HEREON AND DO HEREBY DEDICATE AS FOLLOWS:

1.) TRACT "A1" (DEVELOPMENT TRACT), AS SHOWN HEREON, IS HEREBY RESERVED BY SFG ISF RIVIERA MLK, LLC, A DELAWARE LIMITED LIABILITY COMPANY, AUTHORIZED TO DO BUSINESS IN FLORIDA FOR DEVELOPMENT PURPOSES AND IS THE PERPETUAL MAINTENANCE OBLIGATION OF SAID SFG ISF RIVIERA MLK, LLC, ITS SUCCESSORS AND ASSIGNS, WITHOUT RECOURSE TO THE CITY OF RIVIERA BEACH.

2.) TRACT "B1", (ADDITIONAL RIGHT OF WAY), AS SHOWN HEREON, IS HEREBY DEDICATED AND GRANTED IN FEE SIMPLE TO THE STATE OF FLORIDA DEPARTMENT OF TRANSPORTATION FOR PERPETUAL USE OF THE PUBLIC FOR ROADWAY PURPOSES.

3.) THE CITY OF RIVIERA BEACH UTILITY EASEMENT, AS SHOWN HEREON, IS A EXCLUSIVE EASEMENT AND IS HEREBY DEDICATED IN PERPETUITY TO THE CITY OF RIVIERA BEACH UTILITY SPECIAL DISTRICT, ITS SUCCESSORS AND ASSIGNS, FOR THE INSTALLATION, OPERATION, MAINTENANCE, REPAIR, EXPANSION AND REPLACEMENT OF POTABLE WATER SUPPLY, WASTEWATER SUPPLY AND RELATED APPURTENANCES. IF OTHERWISE APPROVED, NO BUILDINGS, STRUCTURES, IMPROVEMENTS, TREES, WALLS OR FENCES SHALL BE INSTALLED WITHIN THIS EASEMENT WITHOUT THE PRIOR WRITTEN APPROVAL OF THE CITY OF RIVIERA BEACH UTILITY SPECIAL DISTRICT.

IN WITNESS WHEREOF, THE ABOVE-NAMED LIMITED LIABILITY COMPANY HAS CAUSED THESE PRESENTS TO BE SIGNED BY ITS AUTHORIZED SIGNATORY, AND ITS CORPORATE SEAL TO BE AFFIXED HERETO BY AND WITH THE AUTHORITY OF ITS BOARD OF DIRECTORS, THIS \_\_\_\_\_ DAY OF \_\_\_\_\_, 2022.

SFG ISF RIVIERA MLK, LLC,  
A DELAWARE LIMITED LIABILITY COMPANY

WITNESS: \_\_\_\_\_

PRINT NAME: \_\_\_\_\_

WITNESS: \_\_\_\_\_ BY: \_\_\_\_\_

PRINT NAME: \_\_\_\_\_

NEAL MOSKOWITZ  
AUTHORIZED SIGNATORY

## ACKNOWLEDGEMENT

STATE OF FLORIDA)  
COUNTY OF PALM BEACH)

THE FOREGOING INSTRUMENT WAS ACKNOWLEDGED BEFORE ME BY MEANS OF  PHYSICAL PRESENCE OR  ONLINE NOTARIZATION, THIS \_\_\_\_\_ DAY OF \_\_\_\_\_, 2022, BY NEAL MOSKOWITZ AS AN AUTHORIZED SIGNATORY FOR SFG ISF RIVIERA MLK, LLC, A DELAWARE LIMITED LIABILITY COMPANY, ON BEHALF OF THE COMPANY, WHO IS  PERSONALLY KNOWN TO ME OR HAS PRODUCED \_\_\_\_\_ (TYPE OF IDENTIFICATION) AS IDENTIFICATION.

MY COMMISSION EXPIRES: \_\_\_\_\_

NOTARY SEAL

NOTARY PUBLIC

PRINT NAME: \_\_\_\_\_

COMMISSION NUMBER: \_\_\_\_\_

## TITLE CERTIFICATION

STATE OF FLORIDA)  
COUNTY OF PALM BEACH)

I, BRANDON BIONDO, A DULY LICENSED ATTORNEY IN THE STATE OF FLORIDA, DO HEREBY CERTIFY THAT I HAVE EXAMINED THE TITLE TO THE HEREON DESCRIBED PROPERTY; THAT I FIND THE TITLE TO THE PROPERTY IS VESTED IN SFG ISF RIVIERA MLK, LLC, A DELAWARE LIMITED LIABILITY COMPANY; THAT THE CURRENT TAXES HAVE BEEN PAID; THAT ALL MORTGAGES NOT SATISFIED OR RELEASED OF RECORD NOR OTHERWISE TERMINATED BY LAW ARE SHOWN HEREON AND THAT THERE ARE ENCUMBRANCES OF RECORD BUT THOSE ENCUMBRANCES DO NOT PROHIBIT THE CREATION OF THE SUBDIVISION DEPICTED BY THIS PLAT.

DATE: \_\_\_\_\_

BY: \_\_\_\_\_

PRINT NAME: BRANDON BIONDO  
FLORIDA BAR No. 588539

MARCH 2022

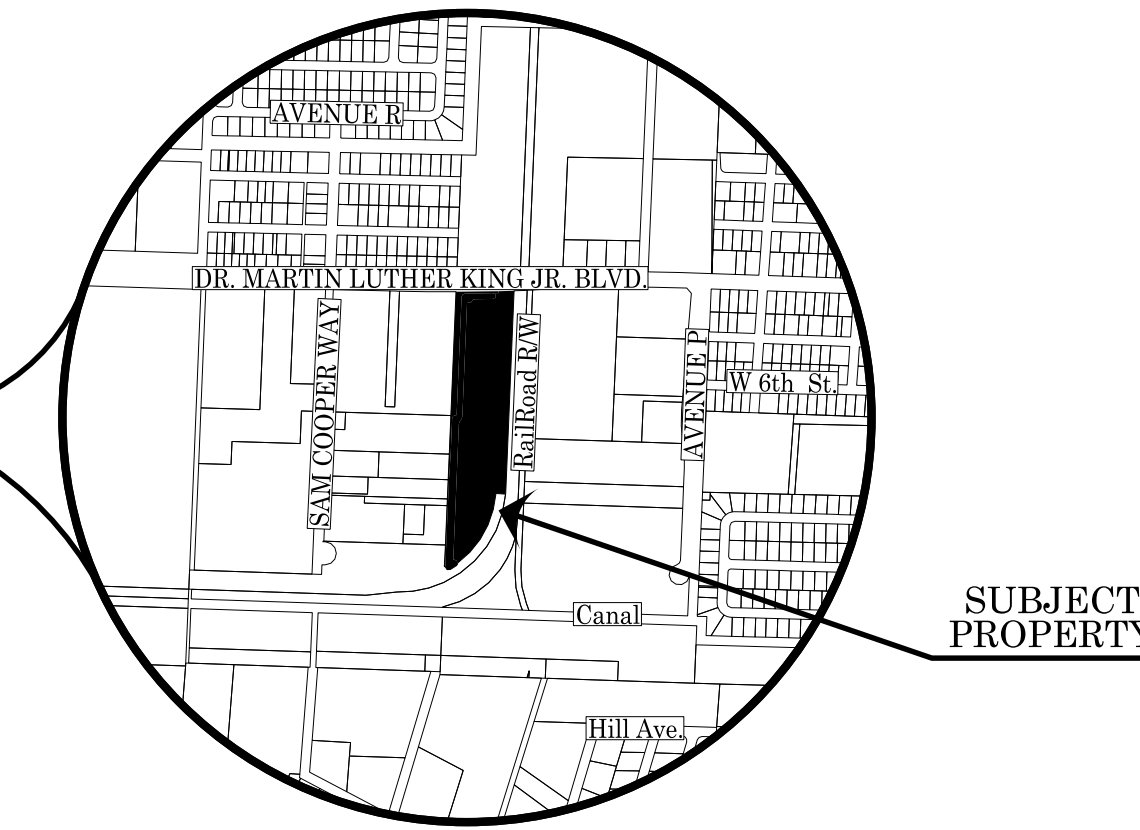
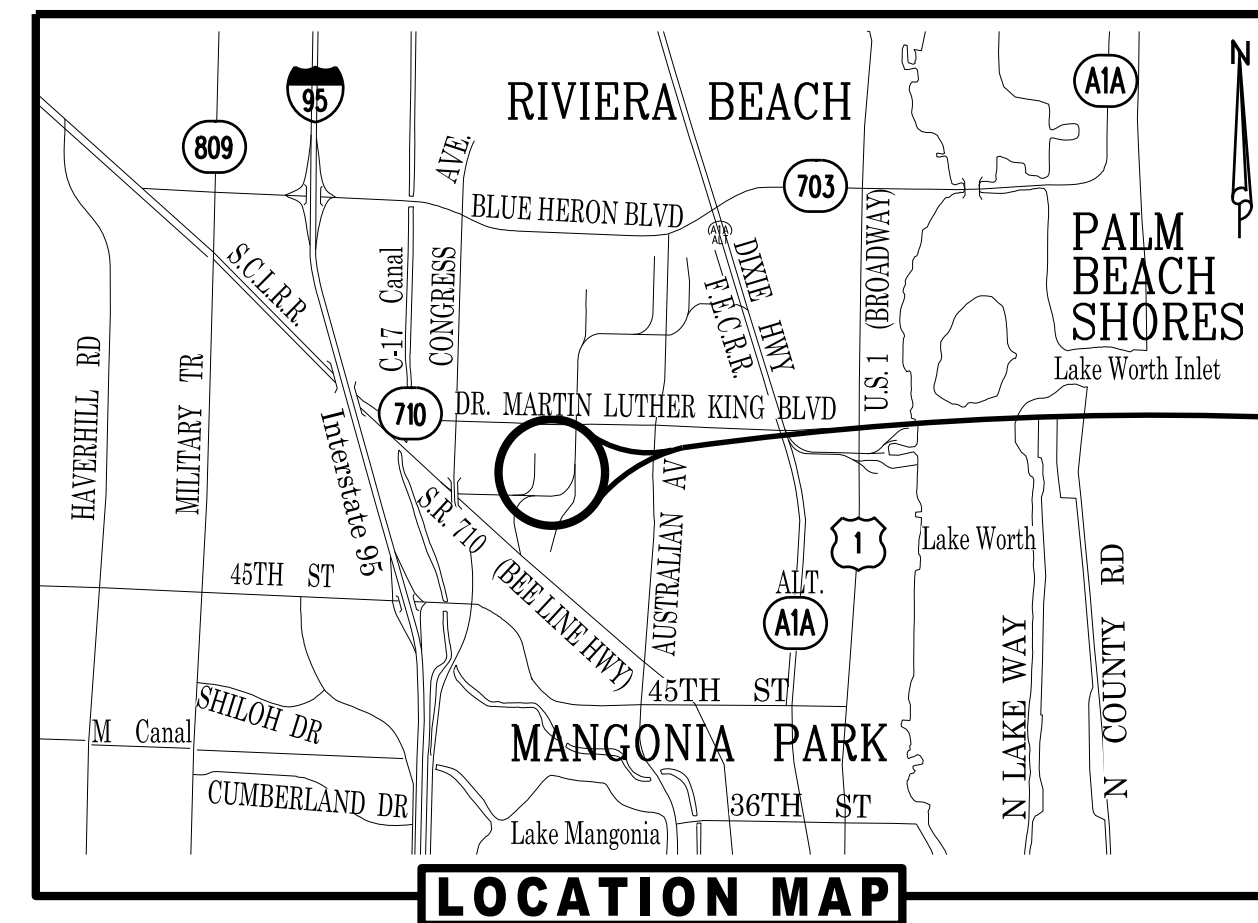

SUBJECT PROPERTY

## MORTGAGEE'S JOINDER AND CONSENT

STATE OF FLORIDA)  
COUNTY OF BROWARD)

THE UNDERSIGNED HEREBY CERTIFIES THAT IT IS A HOLDER OF A MORTGAGE, UPON THE PROPERTY DESCRIBED HEREON AND DOES HEREBY JOIN IN AND CONSENT TO THE DEDICATION OF THE LAND DESCRIBED IN SAID DEDICATION BY THE OWNER THEREOF AND AGREES THAT ITS MORTGAGE WHICH IS RECORDED IN OFFICIAL RECORD BOOK \_\_\_\_\_, PAGE \_\_\_\_\_, PUBLIC RECORDS OF \_\_\_\_\_, FLORIDA, SHALL BE SUBORDINATED TO THE DEDICATION SHOWN HEREON.

IN WITNESS WHEREOF, THE SAID LIMITED LIABILITY COMPANY HAS CAUSED THESE PRESENTS TO BE SIGNED BY ITS \_\_\_\_\_ AND ITS CORPORATE SEAL TO BE AFFIXED HERETO BY AND WITH THE AUTHORITY OF ITS BOARD OF DIRECTORS THIS \_\_\_\_\_ DAY OF \_\_\_\_\_, 2022.

BY: EWE ISF #1 LENDER, LLC  
A FLORIDA LIMITED LIABILITY COMPANY

WITNESS: \_\_\_\_\_

PRINT NAME: \_\_\_\_\_

WITNESS: \_\_\_\_\_ BY: \_\_\_\_\_

PRINT NAME: \_\_\_\_\_

PRINT NAME: \_\_\_\_\_

TITLE: \_\_\_\_\_

## ACKNOWLEDGEMENT

STATE OF FLORIDA)  
COUNTY OF BROWARD)

THE FOREGOING INSTRUMENT WAS ACKNOWLEDGED BEFORE ME BY MEANS OF  PHYSICAL PRESENCE OR  ONLINE NOTARIZATION, THIS \_\_\_\_\_ DAY OF \_\_\_\_\_, 2022, BY \_\_\_\_\_ AS \_\_\_\_\_ FOR EWE ISF #1 LENDER, LLC, A FLORIDA LIMITED LIABILITY COMPANY, ON BEHALF OF THE COMPANY, WHO IS  PERSONALLY KNOWN TO ME OR HAS PRODUCED \_\_\_\_\_ (TYPE OF IDENTIFICATION) AS IDENTIFICATION.

MY COMMISSION EXPIRES: \_\_\_\_\_

NOTARY SEAL

NOTARY PUBLIC

PRINT NAME: \_\_\_\_\_

COMMISSION NUMBER: \_\_\_\_\_

## REVIEWING SURVEYOR

THIS RE-PLAT HAS BEEN REVIEWED FOR CONFORMITY IN ACCORDANCE WITH CHAPTER 177.081(1) OF THE FLORIDA STATUTES AND THE ORDINANCES OF THE CITY OF RIVIERA BEACH, FLORIDA. THIS REVIEW DOES NOT INCLUDE THE VERIFICATION OF THE GEOMETRIC DATA OR THE FIELD VERIFICATION OF PERMANENT REFERENCE MONUMENTS AND PARCEL CORNERS.

DATE: \_\_\_\_\_ BY: \_\_\_\_\_  
GARY M. RAYMAN  
PROFESSIONAL SURVEYOR AND MAPPER  
FLORIDA CERTIFICATE No. 2633

## CITY OF RIVIERA BEACH APPROVALS:

IT IS HEREBY CERTIFIED THAT THIS PLAT "AVENUE S PROPERTIES - REPLAT OF TRACTS A, C AND D" HAS BEEN OFFICIALLY APPROVED FOR RECORD BY THE CITY OF RIVIERA BEACH, FLORIDA THIS \_\_\_\_\_ DAY OF \_\_\_\_\_, 2022.

BY: \_\_\_\_\_  
RONNIE L. FELDER  
MAYOR

BY: \_\_\_\_\_  
CLAUDENE L. ANTHONY, CMC  
CITY CLERK

BY: \_\_\_\_\_  
TERRENCE N. BAILEY, P.E.  
LICENSE No. 60706  
CITY ENGINEER

AS APPROVED ON \_\_\_\_\_, 2022 VIA CITY OF RIVIERA BEACH  
RESOLUTION No. \_\_\_\_\_-22

## SURVEYOR & MAPPER'S NOTES:

1.) BEARINGS SHOWN HEREON ARE GRID AND ARE BASED ON THE NATIONAL GEODETIC SURVEY, NORTH AMERICAN DATUM OF 1983, 1990 ADJUSTMENT (NAD83/90), FLORIDA STATE PLANE TRANSVERSE MERCATOR PROJECTION AND ARE CONSISTENT WITH THE UNDERLYING PLAT OF AVENUE S PROPERTIES, AS SHOWN ON PLAT BOOK 105, PAGES 193 THROUGH 195, PUBLIC RECORDS OF PALM BEACH COUNTY, FLORIDA. THE WEST LINE OF TRACT D (LANDSCAPE AND BUFFER TRACT), AS SHOWN ON SAID PLAT OF AVENUE S PROPERTIES AND AS SHOWN HEREON, BEARS NORTH 02°20'40" EAST.

2.) NO STRUCTURE OR BUILDING OR ANY KIND OF LANDSCAPING SHALL BE PLACED ON OR WITHIN ANY EASEMENT WITHOUT PRIOR WRITTEN CONSENT OF ALL EASEMENT BENEFICIARIES AND THE TOWN ENGINEER.

3.) NOTICE: THIS PLAT, AS RECORDED IN ITS GRAPHIC FORM, IS THE OFFICIAL DEPICTION OF THE SUBDIVIDED LANDS DESCRIBED HEREIN AND WILL IN NO CIRCUMSTANCES BE SUPPLANTED IN AUTHORITY BY ANY OTHER GRAPHIC OR DIGITAL FORM OF THE PLAT. THERE MAY BE ADDITIONAL RESTRICTIONS THAT ARE NOT RECORDED ON THIS PLAT THAT MAY BE FOUND IN THE PUBLIC RECORDS OF THIS COUNTY.

4.) IN THOSE CASES WHERE EASEMENTS OF DIFFERENT TYPES CROSS OR OTHERWISE COINCIDE, DRAINAGE EASEMENTS SHALL HAVE FIRST PRIORITY, UTILITY EASEMENTS SHALL HAVE SECOND PRIORITY, ACCESS EASEMENTS SHALL HAVE THIRD PRIORITY, AND ALL OTHER EASEMENTS SHALL BE SUBORDINATE TO THESE WITH THEIR PRIORITIES BEING DETERMINED BY USE RIGHTS GRANTED.

5.) THIS INSTRUMENT WAS PREPARED BY ERIC CASASUS P.S.M., IN AND FOR THE OFFICES OF LIDBERG LAND SURVEYING, INC., 675 WEST INDIANTOWN ROAD, SUITE 200, JUPITER, FLORIDA 33458. TELEPHONE (561) 746-8454.

## SURVEYOR & MAPPER'S CERTIFICATE:

THIS IS TO CERTIFY THAT THE PLAT SHOWN HEREON IS A TRUE AND CORRECT REPRESENTATION OF A SURVEY MADE UNDER MY RESPONSIBLE DIRECTION AND SUPERVISION; THAT SAID SURVEY IS ACCURATE TO THE BEST OF MY KNOWLEDGE AND BELIEF; THAT PERMANENT REFERENCE MONUMENTS ("P.R.M.'s") HAVE BEEN PLACED AS REQUIRED BY LAW, AND MONUMENTS ACCORDING TO SEC. 177.091(9) F.S., WILL BE SET, FURTHER, THAT THE SURVEY DATA COMPLIES WITH ALL THE REQUIREMENTS OF CHAPTER 177, FLORIDA STATUTES, AS AMENDED, AND THE ORDINANCES OF THE CITY OF RIVIERA BEACH, FLORIDA.

DATE: \_\_\_\_\_ BY: \_\_\_\_\_  
DAVID C. LIDBERG, P.S.M.  
LICENSE No. 3613  
STATE OF FLORIDA

SFG ISF RIVIERA MLK, LLC  
A DELAWARE LIMITED LIABILITY COMPANY

EWE ISF #1 LENDER, LLC,  
A FLORIDA LIMITED LIABILITY COMPANY

CITY OF RIVIERA BEACH ENGINEER  
TERRENCE N. BAILEY  
P.E. No. 60706

CITY OF RIVIERA BEACH CLERK

CITY OF RIVIERA BEACH REVIEWING SURVEYOR  
GARY M. RAYMAN  
P.S.M. No. 2633

DAVID C. LIDBERG  
PROFESSIONAL SURVEYOR  
AND MAPPER

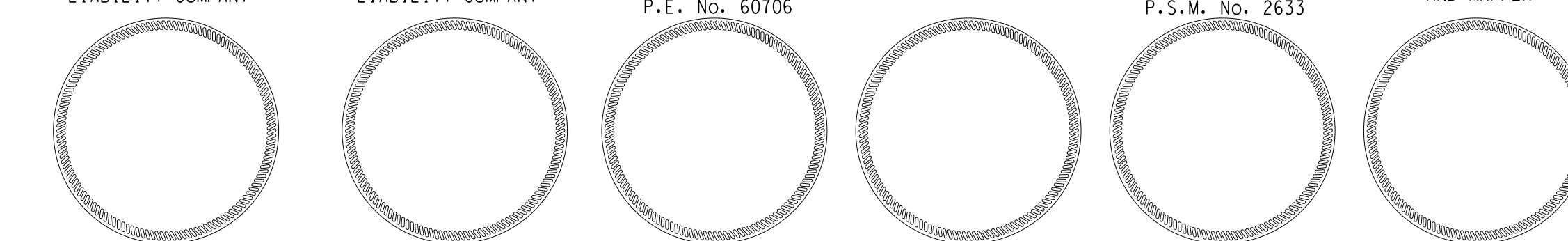

**LIDBERG LAND SURVEYING, INC.**  
675 West Indiantown Road, Suite 200,  
Jupiter, Florida 33458 TEL. 561-746-8454  
LB4431

CAD:	K:\JUST \ 324243 \ 105-193 \ 05-146-306A \ 05-146-306A.DGN		
REF:			
FLD:	PG.	JOB	05-146-306A
OFF:	CASASUS	DATE	MARCH 2022
CKD:	D.C.L.	SHEET	1 OF 2 DWG. 005-146P

# AVENUE S PROPERTIES - REPLAT OF TRACTS A, C AND D

BEING A REPLAT OF TRACTS A, C AND D, AS SHOWN ON THE PLAT OF AVENUE S PROPERTIES,  
AS RECORDED IN PLAT BOOK 105, PAGES 193 THROUGH 195, PUBLIC RECORDS OF PALM BEACH COUNTY, FLORIDA  
LYING IN SECTION 32, TOWNSHIP 42 SOUTH, RANGE 43 EAST  
CITY OF RIVIERA BEACH, PALM BEACH COUNTY, FLORIDA

MARCH 2022

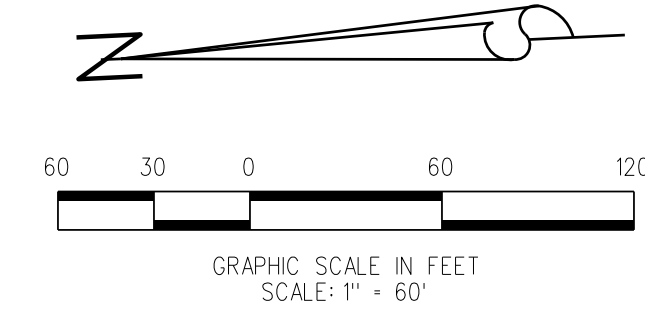

SHEET 2 OF 2

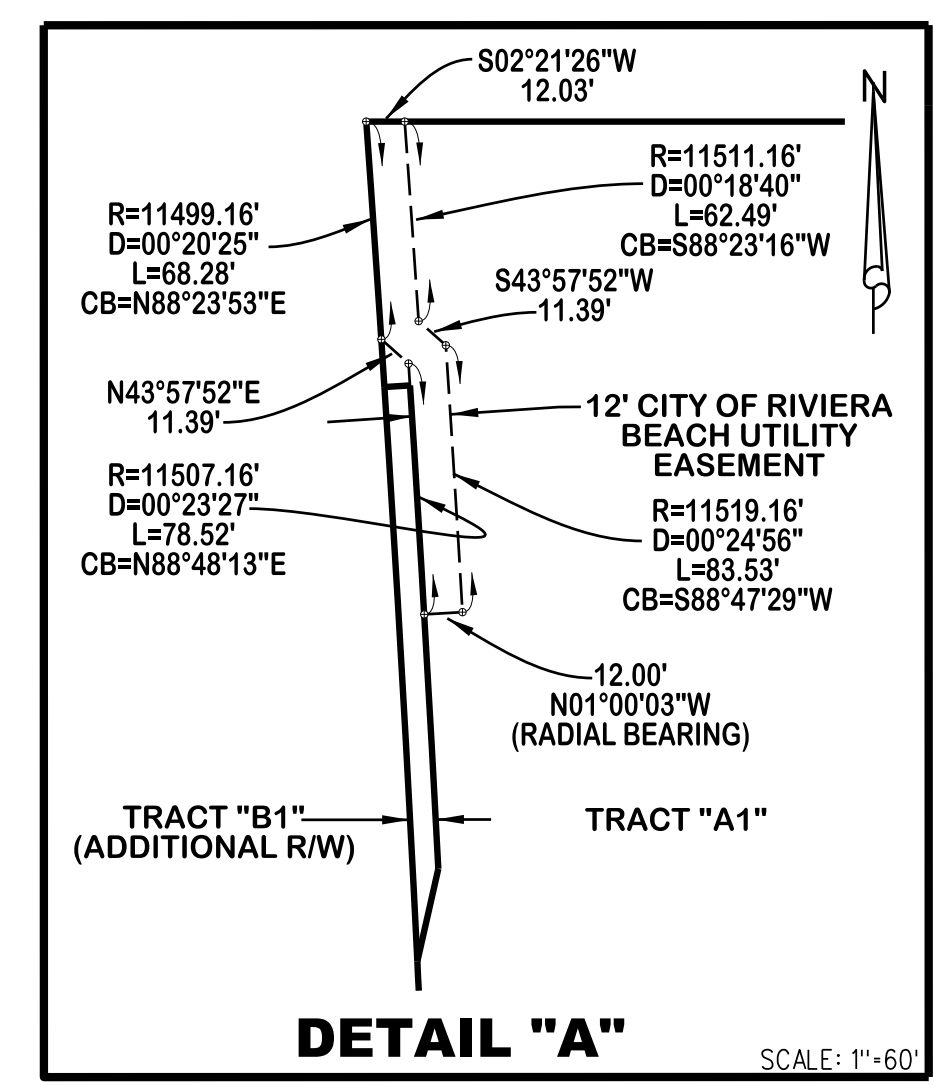
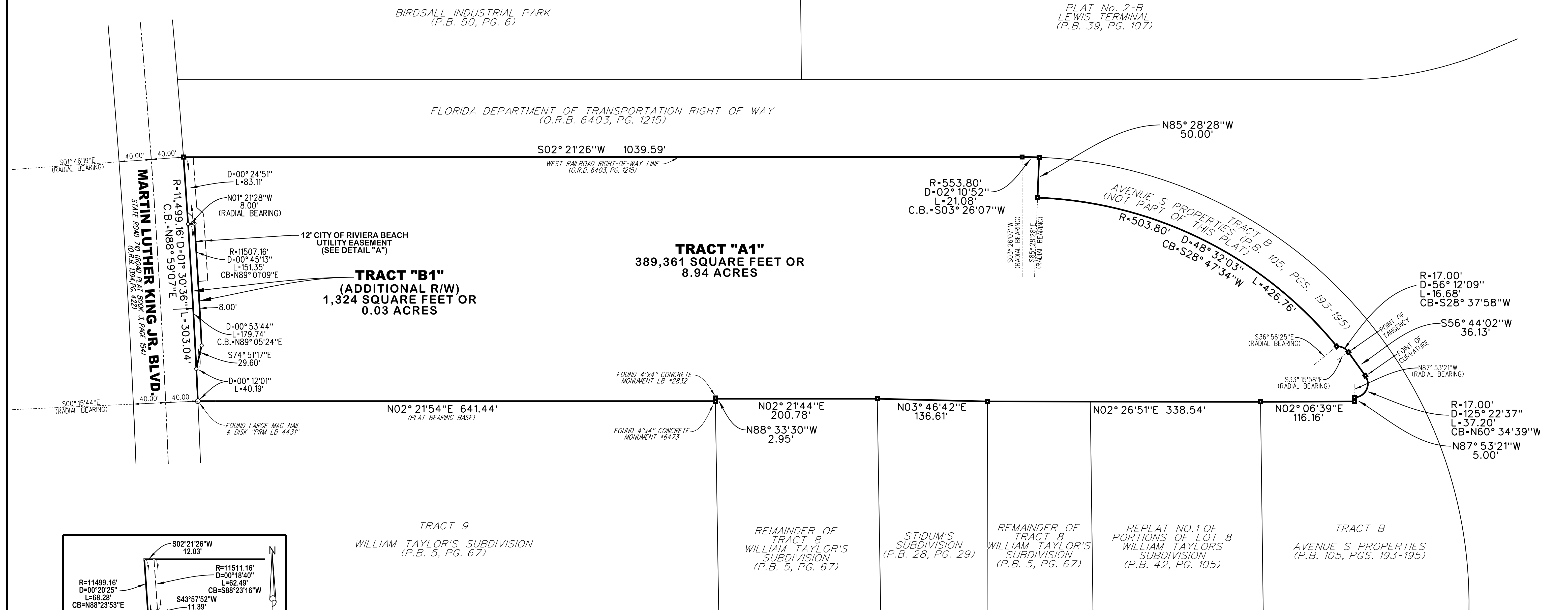

- ABBREVIATIONS:**
- CB = CHORD BEARING
  - D = CURVE'S DELTA ANGLE
  - L = CURVE'S ARC LENGTH
  - MON. = MONUMENT
  - O.R.B. = OFFICIAL RECORD BOOK
  - P.B. = PLAT BOOK
  - PG. = PAGE
  - PGS. = PAGES
  - PRM = PERMANENT REFERENCE MONUMENT
  - R = CURVE'S RADIUS
  - W/ = WITH
- LEGEND:**
- DENOTES FOUND 4"x4" CONC. MON. W/ DISK STAMPED "PRM LB 4431" UNLESS OTHERWISE NOTED
  - DENOTES SET 4"x4" CONC. MON. W/ DISK STAMPED "PRM LB 4431"

**LIDBERG LAND SURVEYING, INC.**  
675 West Indiantown Road, Suite 200,  
Jupiter, Florida 33458 TEL. 561-746-8454

CD:	K:\JUST \ 324243 \ 105-193 \ 05-146-306A \ 05-146-306A.DGN		
REF.			
FLD.	PG.	JOB	05-146-306A
OFF.	CASASUS	DATE	MARCH 2022
CKD.	D.C.L.	SHEET	2 OF 2
		DWG.	005-146P

# AVENUE S PROPERTIES - REPLAT OF TRACTS A, C AND D

BEING A REPLAT OF TRACTS A, C AND D, AS SHOWN ON THE PLAT OF AVENUE S PROPERTIES,  
AS RECORDED IN PLAT BOOK 105, PAGES 193 THROUGH 195, PUBLIC RECORDS OF PALM BEACH COUNTY, FLORIDA  
LYING IN SECTION 32, TOWNSHIP 42 SOUTH, RANGE 43 EAST  
CITY OF RIVIERA BEACH, PALM BEACH COUNTY, FLORIDA

MARCH 2022

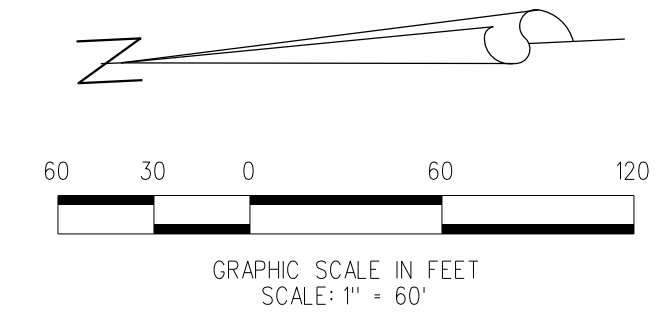

SHEET 2 OF 2

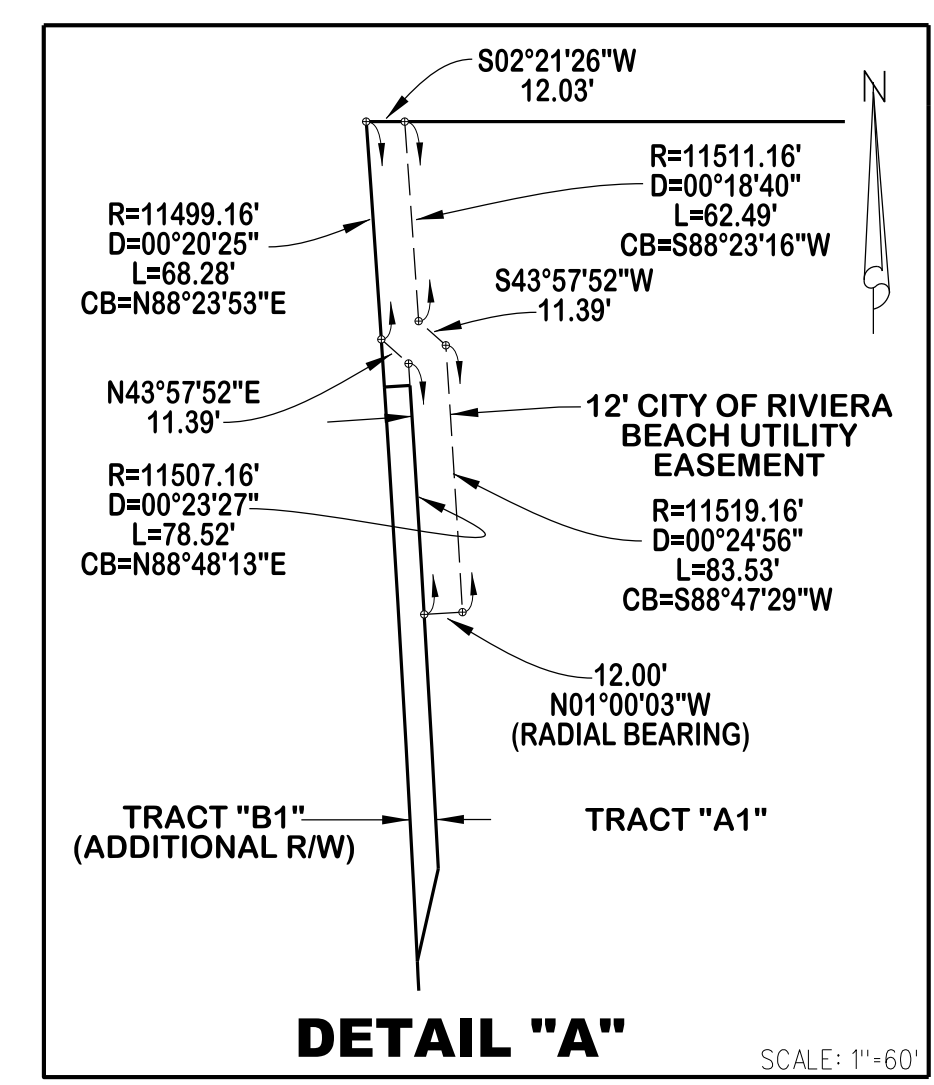
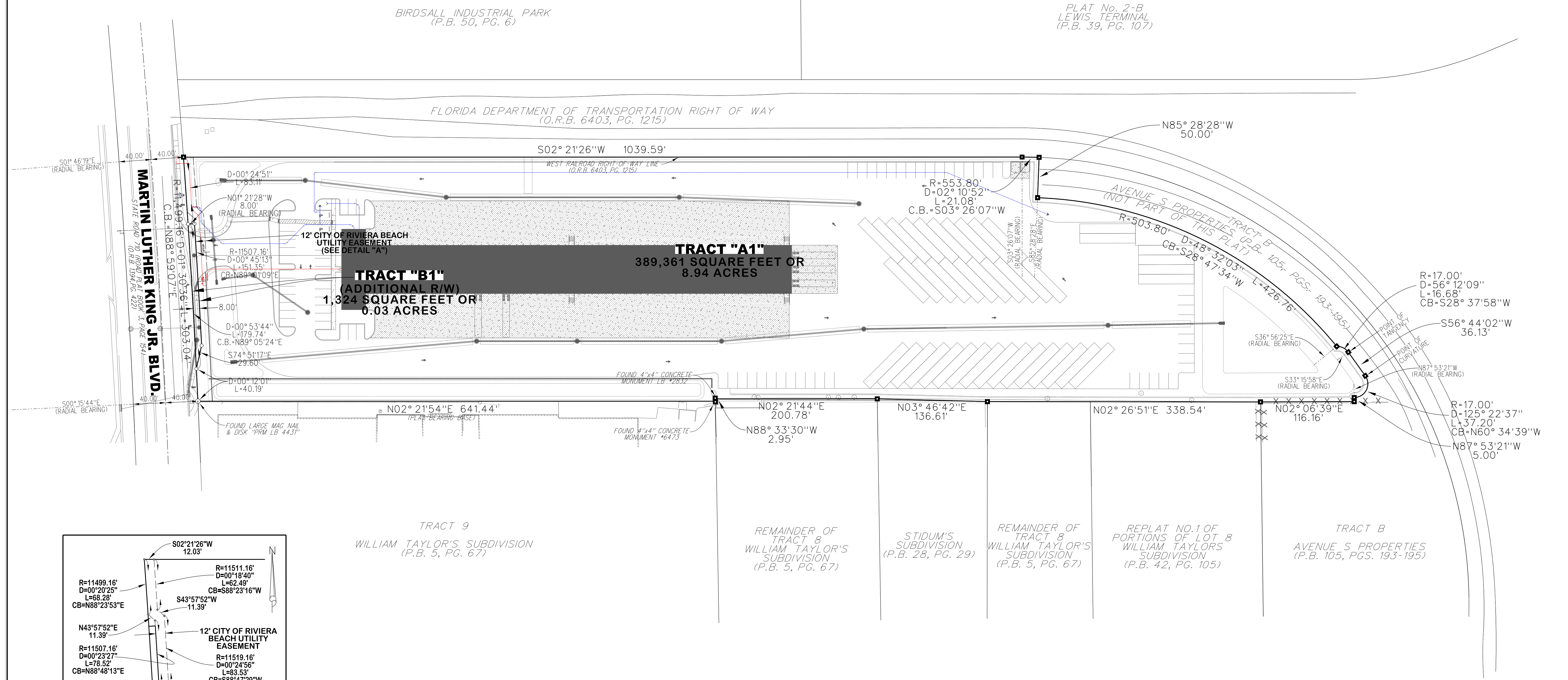

- ABBREVIATIONS:**
- CB = CHORD BEARING
  - D = CURVE'S DELTA ANGLE
  - L = CURVE'S ARC LENGTH
  - MON. = MONUMENT
  - O.R.B. = OFFICIAL RECORD BOOK
  - P.B. = PLAT BOOK
  - PG. = PAGE
  - PGS. = PAGES
  - PRM = PERMANENT REFERENCE MONUMENT
  - R = CURVE'S RADIUS
  - W/ = WITH
- LEGEND:**
- DENOTES FOUND 4"x4" CONC. MON. W/ DISK STAMPED "PRM LB 4431" UNLESS OTHERWISE NOTED
  - DENOTES SET 4"x4" CONC. MON. W/ DISK STAMPED "PRM LB 4431"

**LIDBERG LAND SURVEYING, INC.**  
675 West Indiantown Road, Suite 200,  
Jupiter, Florida 33458 TEL. 561-746-8454  
LB4431

CAD:	K:\JUST \ 324243 \ 105-193 \ 05-146-306A \ 05-146-306A.DGN		
REF.			
FLD.	PG.	JOB	05-146-306A
OFF.	CASASUS	DATE	MARCH 2022
CKD.	D.C.L.	SHEET	2 OF 2
		DWG.	D05-146P